

# Controlling Pocket Gopher Damage to Conifer Seedlings

D.S. deCalesta, K. Asman, and N. Allen

## Contents

Gopher habits and habitat .....	1
Control program .....	2
<i>Identifying the pest</i> .....	2
<i>Assessing the need for treatment</i> ...	3
<i>Damage control techniques</i> .....	3
Applying controls .....	7
<i>Christmas tree plantations</i> .....	7
<i>Forest plantations</i> .....	7
Summary .....	8
Sources of supply .....	8
For further information .....	8

**P**ocket gophers (or just plain “gophers”) damage conifer seedlings on thousands of acres in Washington, Idaho, and Oregon annually. They invade clearcuts and clip (cut off) roots or girdle (remove bark from) the bases of conifer seedlings and saplings, causing significant economic losses.

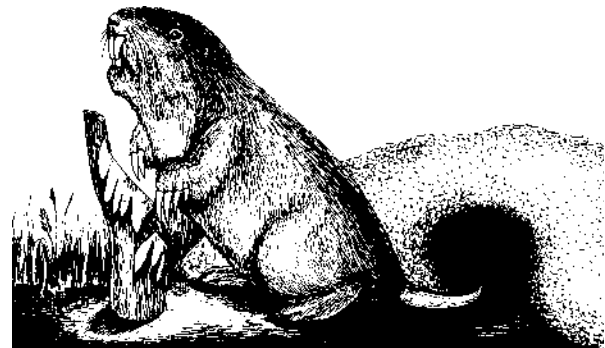

Figure 1.—Typical Oregon pocket gopher.

This publication will help you design a program to reduce or eliminate gopher damage to seedlings and saplings in your forest plantation or Christmas tree farm.

First, we describe pocket gophers, their habits, and habitats. Then we discuss procedures for controlling pocket gopher damages—control techniques, their effectiveness and hazard(s) to the environment, and their use under a variety of tree-growing situations.

## Gopher habits and habitat

Three species of pocket gopher can damage conifer seedlings. The two smaller ones, the northern pocket gopher and the Mazama pocket gopher, are 5 to 9 inches long and brown with some white beneath the chin and belly. The northern gopher is found east of the Cascade Mountains in Oregon and Washington and in Idaho; the Mazama lives in Oregon and Washington west of the Cascades.

The Camas pocket gopher is similar looking, but larger (10 to 12 inches) than the two others. It lives in Oregon north of Eugene in the Willamette Valley, including the foothills of the Coast and Cascade ranges.

All are easily identified by their fur-lined external cheek pouches and large orange front teeth, which are used to clip roots and dig tunnels. They have powerful front legs and large, curved claws for burrowing (Figure 1).

*David S. deCalesta, former Extension wildlife specialist, and Kim Asman, formerly College of Forestry, both of Oregon State University; revised by Nancy Allen, Extension wildlife instructor, Oregon State University.*

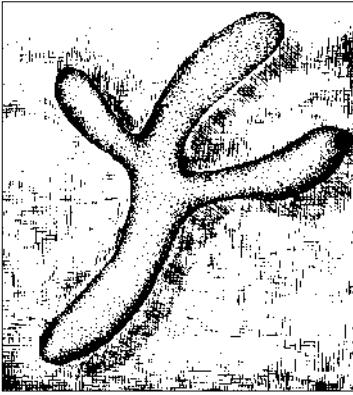

Figure 2.—Earthen “casts” left above ground by gophers tunnelling through snow.

They spend most of their lives in their extensive burrow systems, which usually are 4 to 12 inches underground and can contain over 500 feet of tunnels.

Gophers feed mostly above ground on grasses and weeds close to the burrow opening. They also feed underground on the roots of forbs, shrubs, and trees. Most girdling of seedlings and saplings is in eastern Oregon and Wash-

ington during winter, when the gopher’s burrow system extends above ground into the snow.

The soil that gophers push out into these snow tunnels forms the curious casts or worm tracks left on the surface of the ground after snowmelt (Figure 2).

Gophers inhabit small forest openings where they find their preferred foods. Such openings are natural meadows or have been created by clearcut logging.

Within months, gophers invade regeneration sites from adjacent clearcuts or meadows. Gophers can travel more than 300 feet above ground and 2,500 feet under snow cover when moving from established forest openings to new clearcuts.

Gophers are solitary except during the breeding season.

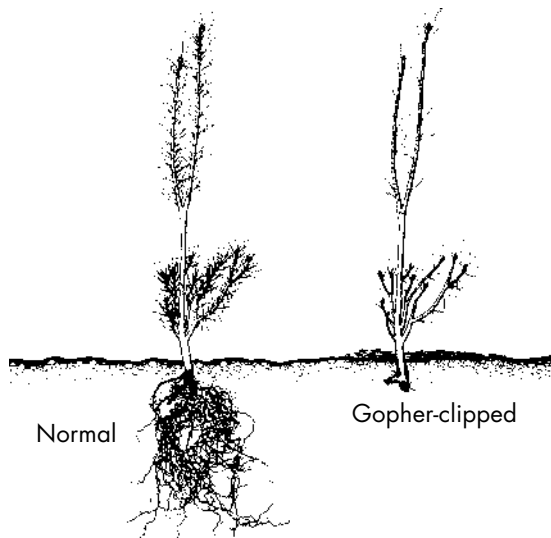

Figure 3.—Typical gopher clipping damage to a seedling’s root system.

Mating is in early spring; four to eight young are born 3 weeks later. In early summer, the young are driven from the female’s burrow to establish their own systems. Gophers breed at 1 year of age, usually have only one litter a year, and have a life expectancy of 1 to 3 years.

Gopher density varies with habitat conditions, ranging from four to twenty per acre. In areas with abundant food, burrow systems are shorter and gopher densities are higher.

## Control program

### Identifying the pest

Identification is based on characteristics of damage and burrow systems. Physical characteristics of gopher damage are unique. Gophers clip roots and rootlets, leaving only the main stem of the seedling (Figure 3). Needles of gopher-damaged seedlings wilt and turn brown, and the seedling can be pulled out of the ground easily.

Gophers may pull entire seedlings below ground. They girdle seedlings and saplings, especially during winter. Girdled seedlings/saplings look “sculpted” (Figure 4). Individual toothmarks are  $\frac{1}{16}$  inch wide. A gopher burrowing through snow can girdle conifer stems as high as snow depth, which may be 7 feet or more above ground.

Voiles, like pocket gophers, damage seedlings by girdling, but their teeth are so small that gnawed bark looks fuzzy. Vole toothmarks are about  $\frac{1}{32}$  inch wide.

Porcupines occasionally girdle conifers at ground level, but their toothmarks ( $\frac{1}{8}$  inch wide) are twice as large as those of gophers.

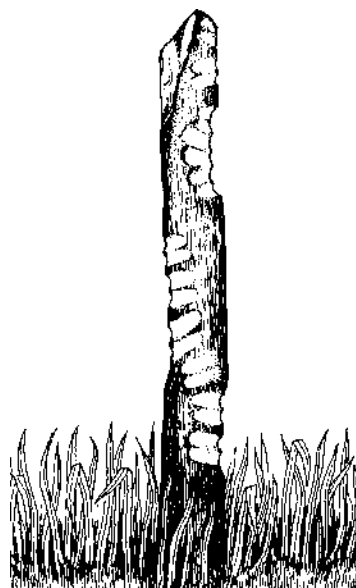

Figure 4.—A “sculpted” (girdled) seedling, which is typical gopher damage.

Gophers' system of mounds, earth plugs, and winter casts is distinctive. The mound is horseshoe- or fan-shape (Figure 5). Gophers push soil up lateral (side) tunnels and spread it around the opening (about 2 inches wide) at one edge.

Mole mounds look like those of pocket gophers, but they are volcano- rather than fan-shape and the opening is in the center of the mound.

The mound pattern of pocket gophers is different from that of moles. Moles push up a series of single mounds in nearly straight lines, but gophers cluster mounds in irregular groupings (Figure 6).

Voies burrow but do not mound dirt at the tunnel entrance. Their openings (about the size of a fifty-cent piece) are smaller than those of gophers and are interconnected by aboveground trails.

## Assessing the need for treatment

Determining the need to control gopher damage should be part of your harvest and reforestation planning. The standard method is to measure gopher activity by the mound survey, which is an index of gopher numbers.

To assess gopher numbers, check plots of one-tenth acre (square areas 20 feet on a side, or circles with 24-foot diameters) for presence of gopher mounds. One one-tenth-acre plot per acre of regeneration site is required to accurately assess the need for gopher control. Usually, plots are laid out on lines (transects) across regeneration sites so that adjacent plots are at least 150 feet apart (Figure 7, page 4).

Begin your control measures on sites up to 2 years old if 25 percent or more of the plots contain active mounds, and on sites 3 to 5 years old if 40 percent or more of the plots contain active mounds.

## Damage control techniques

You'll achieve maximum effectiveness of most control techniques if you can employ them *before* you plant seedlings. Most forest managers are willing to apply control techniques before planting only if

damage is very likely—that's why it's important to conduct your mound survey.

Where it's possible, combine several control techniques. This will give better results than if you use just one.

**Fumigating** Fumigants (cartridges and pellets) release poison gases (carbon monoxide and sulfur dioxide) into the gopher's burrow system. They are most effective when the soil is damp—when you squeeze a handful, it forms a ball rather than crumbling.

Fumigants won't work when the soil is dry because the gas leaks. Fumigants work best in spring or fall when soil is moist and gophers are most active (their mounds are easier to spot then, too).

Open the burrow tunnel down to the main runway with a shovel or trowel. Ignite and place a gas cartridge (or two or three pellets) 6 to 10 inches down the opened runway. Stuff newspaper in the burrow entrance and cover with several shovelfuls of soil to block escape of poison gas.

If the gas doesn't kill the gopher, the gopher usually clears its runway of residual gas by digging many exit holes near the burrow entrance. Then, use trapping or poison baiting as additional treatment.

Another way to gas gophers is to use a hand-held propane weed burner (Figure 8, page 4) and dusting sulfur.

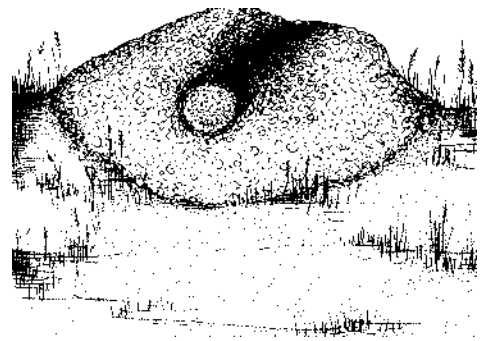

Figure 5.—A typical gopher mound.

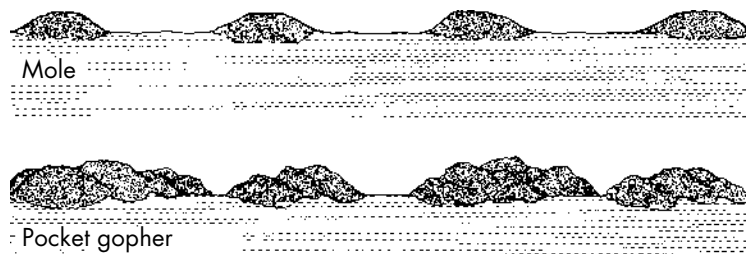

Figure 6.—Mole mounds are easily distinguished from pocket gopher mounds.

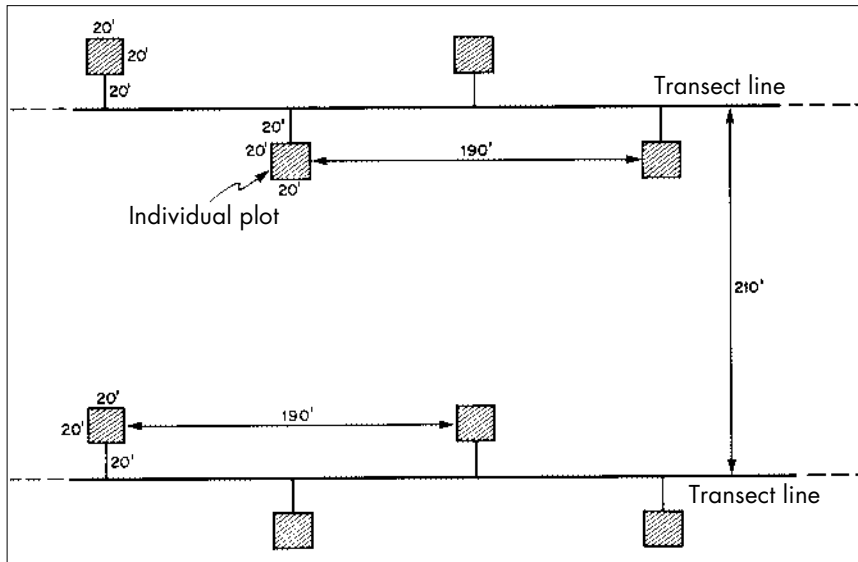

Figure 7.—Layout of plots on transect lines for assessing need to control gopher damage.

Open the burrow down to the main runway and place about 1 cup of dusting sulfur in the burrow entrance. Turn the gas on full force and light it. The flaming propane will ignite the sulfur.

The sulfur burns best when you hold the torch about 6 inches away. Thick, white smoke will begin to seep from other burrow entrances; cover these with shovelfuls of soil. The sulfur burns up in about 30 seconds. Cover the burrow entrance with soil when you've finished burning the sulfur.

Fumigating is time consuming, so use it only when you need to treat areas less than 5 acres. Fumigating poses minimal risk to nontarget animals because it's used only in active gopher burrow systems—and gophers don't tolerate other animals in their burrows. Fumigating, like other lethal control methods, usually must be repeated to get the gophers you missed with the first application.

To determine whether you need to treat again, flatten all gopher mounds when you fumigate. Return in a week and treat all burrow systems where the mounds have been rebuilt.

They are a sign that you didn't eliminate all gophers with the first treatment.

Gophers from adjacent areas will invade rapidly and use tunnel systems of gophers killed in control programs. To prevent reinfestation, fumigate gopher burrows in a buffer area 300 feet wide outside your regeneration site.

**Trapping** is effective but time consuming, so trap small areas (less than 5 acres) or in places where poison baits can't be used. Follow up fumigating or poison baiting with trapping to remove gophers resistant to gas or baits.

Use Victor or Macabee traps.

Locate the main runway of the burrow system by pushing a probe (an iron rod, Figure 9) repeatedly in the ground in the area between two adjacent fresh mounds. You'll know when you hit the runway because the probe suddenly will sink 2 to 4 inches in the ground. Dig an opening down into the runway and place two traps as shown in Figure 10.

Anchor the traps with wire and flag them to make relocation easy and to prevent scavengers from dragging away traps with dead gophers. Leave the opening partially open; this will attract the gopher to the trap area. The gopher will be caught coming in either direction as it attempts to plug the open runway.

You may put traps in lateral runways at the mouths of opened burrows, but your success will be higher when you place them

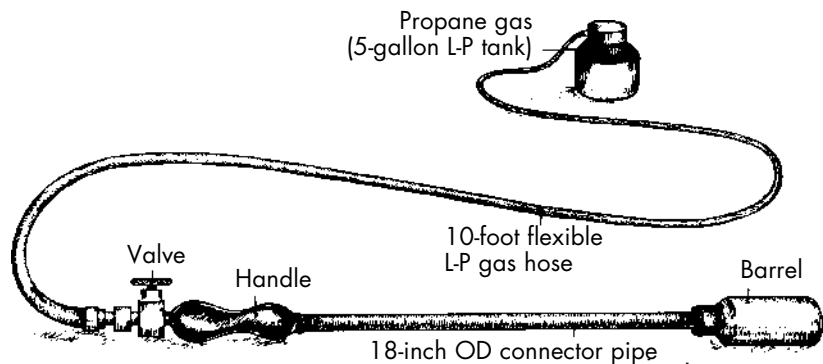

Figure 8.—Hand-held propane "gopher gasser."

in the main runway. Trap in fall and spring when the soil is softer and easier to dig and gophers are creating new mounds more actively. Trap a buffer zone 300 feet wide outside the regeneration site if possible.

Trapping, like fumigating, doesn't eliminate all pocket gophers, so you'll need to return to eliminate surviving gophers. Just as you did for fumigating, flatten all mounds the first time you set the traps and retrap all burrow systems where the mounds are rebuilt a week later.

**Poison baiting** Poison baits are extremely effective for controlling gopher damage. Grain baits containing 0.3 to 0.5 percent strychnine alkaloid are available at many farm and garden supply stores.

Baiting is hazardous not only to small mammals (such as voles, chipmunks, and golden-mantled ground squirrels) that eat baits in gopher burrows but also to hawks, owls, and mammalian predators and scavengers (weasels, skunks, foxes, coyotes, and bobcats) that feed on gophers.

Hazard to predators and scavengers is low because most poisoned gophers will die in the burrow system and be unavailable to these animals. If seed baits are spilled

above ground and not cleaned up, they pose a serious hazard to seed-eating birds, which are highly susceptible to strychnine.

Poison baiting is most effective in early spring, when natural gopher foods are in low supply.

Locate main runways with a probe. Rotate the probe in a circle several times to enlarge the hole, then remove the probe and drop 1 teaspoon of bait into the tunnel. Close the hole with a dirt clod.

If the opening is left open, the gopher will plug the runway at that point, covering the bait. **Never** scatter bait around the burrow entrance—birds will be poisoned if you do. Make three to five bait placements per cluster of fresh mounds.

You can bait with a probe-bait dispenser (Figure 11, page 6). This device cuts treatment time in half because you probe and place bait in one step. Be sure to use only grain baits because pelleted baits will jam in probe-bait dispensers.

Locate the main runway using the dispenser as a probe. Push a button or lever on the dispenser to release a measured amount of bait into the tunnel, then pull the dispenser from the ground. Cover the resulting small hole with a rock or clod. Probe-bait

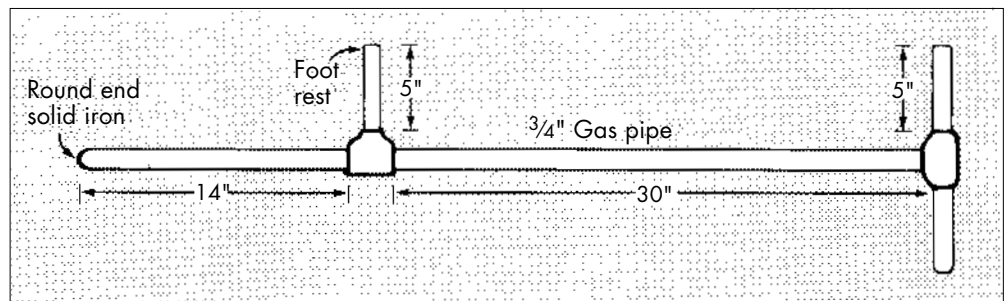

Figure 9.—Probe used to locate gopher tunnel system.

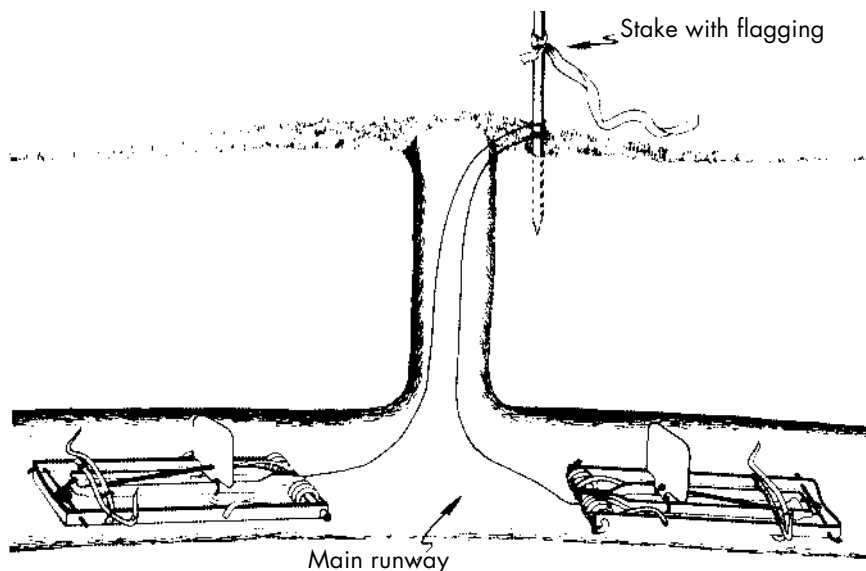

Figure 10.—Correct placement of gopher traps.

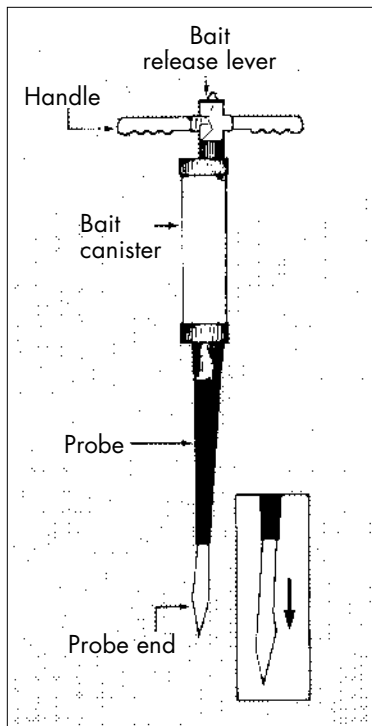

Figure 11.—Probe-bait dispenser.

dispensers work poorly in summer in soils with a high clay content because the probe can't penetrate these soils when dry.

For treating fairly flat areas of more than 10 acres, you can bait with the burrow builder (Figure 12). You pull a burrow builder behind a tractor to create artificial gopher burrows. Burrow builders automatically dispense poison baits into the artificial tunnels. Gophers investigate these artificial burrows and encounter and eat the baits. If strychnine alkaloid is labeled for use with a burrow builder, then that formulation is a restricted-use pesticide, and a certified applicator's

license is required to use it.

Burrow builders disperse poison baits ten times faster than hand baiting, but their use is restricted to areas with slopes of less than 20 percent and soil relatively free of rocks, roots, and debris. The surface of the ground must be relatively free of slash.

Burrow builders work well only with seed baits (pelleted baits jam in the device), and they require a tractor with a minimum of 25 horsepower.

Like the probe-bait dispenser, the burrow builder is most effective when soil is moist, in late fall and early spring. (For more information on using the burrow builder, see OSU Extension publication EC 1117,

#### *Controlling Pocket Gopher Damage to Agricultural Crops.*)

When you bait sites larger than 20 acres, it's too time consuming to flatten and check each mound after baiting to determine the need for

retreatment. Use the "open-burrow survey" to measure reduction in gopher activity resulting from control methods.

Establish 40 or more square sampling plots, 20 feet on a side and at least 100 feet apart, before applying poison baits. Open the entrances of all active gopher burrows within each plot. Examine the plots 24 to 48 hours later to determine gopher activity (i.e., to see whether opened burrows are plugged) and to record the number of plots with gopher activity.

Repeat the survey 1 to 2 weeks after you apply poison baits. To see how much you reduced pretreatment activity, divide the number of plots with gopher activity after treatment by the number before treatment, then multiply by 100. Rebait sites with more than 20 percent gopher activity.

**Manipulating habitat** Gophers respond directly to changes in availability of preferred foods. When you eliminate grasses and forbs by applying herbicides, the numbers of gophers and the damage to conifer seedlings drop. Timing is important if you plan to use vegetation management to control gopher damage.

Plant your conifer seedlings well *after* you remove grasses and forbs (even as long as 1 year). If you plant too soon, the gophers will find only seedlings to eat after their preferred foods are eliminated—and they'll devour every seedling.

Habitat manipulation only *reduces* gopher numbers and damage, so you'll need to follow up with lethal controls to remove remaining gophers.

Postharvest treatments before planting should create a favorable site for seedlings but not for gophers. If you use broadcast

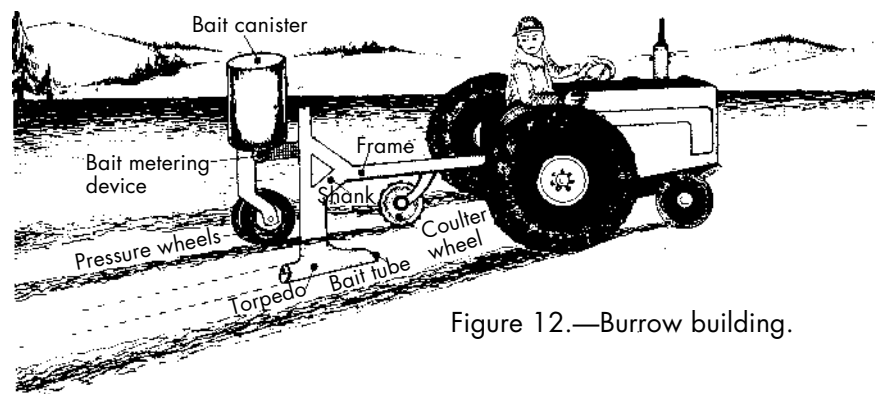

Figure 12.—Burrow building.

burning, monitor the herbaceous reinvasion and reduce it when necessary, if doing so doesn't conflict with using these plants as forage for livestock.

Minimize soil disturbance; it makes tunneling easier for gophers and opens up a bare soil seedbed for forbs and grasses.

Another habitat manipulation you can try enhances gopher predation by hawks and owls. These birds use perching poles (15 to 20 feet high) for hunting. If you leave a small number of snags (one or two per acre) scattered across regeneration sites after preparation, these perches could attract enough raptors to reduce your gophers.

**Seedling protectors** Plastic netting or Vexar tubing placed around seedlings reduces gopher damage. Place the tube around the seedling, to protect the stem and roots, and plant it with the seedling.

The tube's photodegradable plastic breaks down after 3 to 5 years in sunlight. Little is known about the plastic's degradation underground or about its effects on root development, but preliminary studies indicate no negative effect, and gopher damage is prevented.

---

## Applying controls

### Christmas tree plantations

Many plantation sites were grass fields before being planted to conifers. Such sites often provide excellent food and cover for gophers. Managing grass and forb vegetation is extremely important: the fewer the forbs and grasses, the fewer gophers there will be.

However, don't plant such sites until at least 6 to 12 months after you remove grass and forbs and have eliminated surviving gophers by trapping and/or handbaiting.

You can discourage gopher entry into the site by maintaining a buffer zone free of forage plants 300 feet around the perimeter of plantations. However, this may not be practical or feasible.

After you've controlled grass and forb vegetation, periodic site inspections will

reveal any gopher invasion. Deal with these promptly by trapping, baiting, or both. If a Christmas tree plantation is heavily infested, applying baits with a burrow builder (see page 6) is the quickest and cheapest solution.

### Use pesticides safely!

- **Wear** protective clothing and safety devices as recommended on the label. **Bathe or shower** after each use.
- **Read** the pesticide label—even if you've used the pesticide before. **Follow closely** the instructions on the label (and any other directions you have).
- **Be cautious** when you apply pesticides. **Know** your legal responsibility as a pesticide applicator. You may be liable for injury or damage resulting from pesticide use.

### Forest plantations

Managing vegetation is a key to keeping gopher damage to a minimum. If possible, eliminate foods and cover from regeneration sites through burning and/or herbicide use. If you can manage the vegetation in this manner, a yearly inspection of regeneration sites will reveal any small-scale gopher invasions. You can treat these promptly and efficiently with hand baiting, trapping, or both.

For regeneration sites with established populations, the traditional control method is to contract probe-baiting out to a professional consulting service (usually two applications, with a follow-up to establish effectiveness). If you can use the burrow builder, you'll greatly speed up the baiting process, and you may be able to bait a buffer zone.

In areas with high winter girdling loss and deer and elk damage, you might consider using Vexar tubing. Plant the tubing around the roots, extending 8 to 10 inches below ground and extending 1 foot or more (as high as typical snow depth) above ground, to provide dual protection against browsing by deer and elk and against winter girdling by pocket gophers.

Vexar tubing tends to collapse from the weight of snow, and snow movement tends to pull it away from the seedling. The answer is to fix the tubes in place with two

bamboo sticks threaded through the Vexar mesh. Once the sites are free of snow in the spring, inspect the tubes for distortions or movement and restore them to the proper configuration to protect the seedlings.

---

## Summary

Successful management of gopher damage can be achieved by:

1. Managing grass and forb vegetation to eliminate gopher foods and prevent much damage
2. Selecting and applying appropriate control techniques that are compatible, rather than in conflict, with other silvicultural practices, and
3. Assessing effectiveness of your control program within 3 to 6 months, which will ensure that you used correct methods and will allow time to reapply controls if your first attempts were unsuccessful

---

## Sources of supply

Here are some major manufacturers of probe-baiting dispensers and burrow builders. This list isn't exhaustive, and it's not an endorsement by the Oregon State University Extension Service. Ask the OSU Extension office that serves your county for a list of nearby distributors.

### Probe-baiting dispensers

RCO, Inc.  
P.O. Box 191  
Harrisburg, OR 97446  
Tel. 541-995-7799

### Burrow builders

RCO, Inc.  
(address and phone as above)  
All American Ag  
724 Woodard Canyon  
Touche, WA 99360  
Tel. 509-394-2910

---

## For further information

deCalesta, D.S. *Controlling Pocket Gopher Damage to Agricultural Crops*, EC 1117. 1999. Corvallis: Oregon State University Extension Service.

Order from:  
Publication Orders  
Extension & Station Communications  
Oregon State University  
422 Kerr Administration  
Corvallis, OR 97331-2119  
Tel. 541-737-2513  
Fax 541-737-0817  
e-mail [puborders@oregonstate.edu](mailto:puborders@oregonstate.edu)

Please contact the above office for information on current publication prices and availabilities and shipping and handling charges. Or, visit us on the Web at <http://eesc.oregonstate.edu/>