

# 1 KNOWLEDGE ADVANCEMENTS

1. In the table below, list three different horse breeds and the following information about them.

|                  |  |  |  |
|------------------|--|--|--|
| Breed:           |  |  |  |
| Origin:          |  |  |  |
| Characteristics: |  |  |  |
| Primary uses:    |  |  |  |

2. What are the five basic coat colors? Name and briefly describe them.

- 1.
- 2.
- 3.
- 4.
- 5.

3. What are the five major variations to the basic coat colors? Name and briefly describe them.

- 1.
- 2.
- 3.
- 4.
- 5.

4. On the pictures below, draw the following face markings: star, stripe, blaze, snip, and bald face.

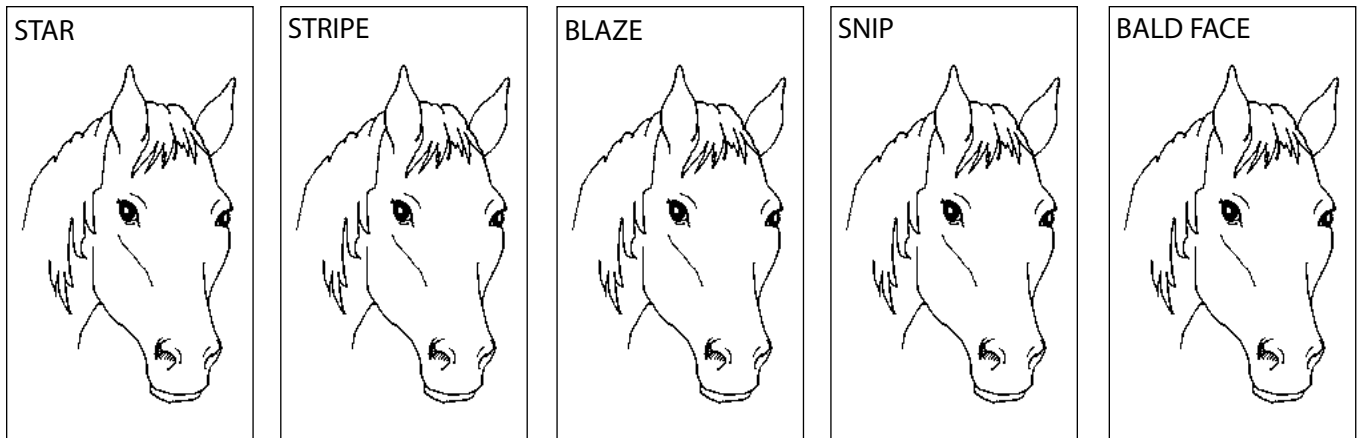

# KNOWLEDGE ADVANCEMENTS (contd.)

5. Identify the following parts of the hunt seat saddle.  
Write their names in the boxes.

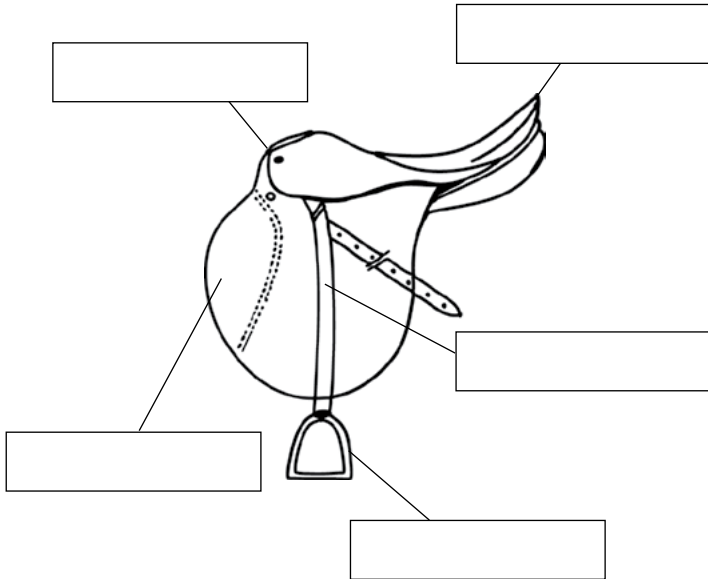

6. Identify the following parts of the English bridle.  
Write their names in the boxes.

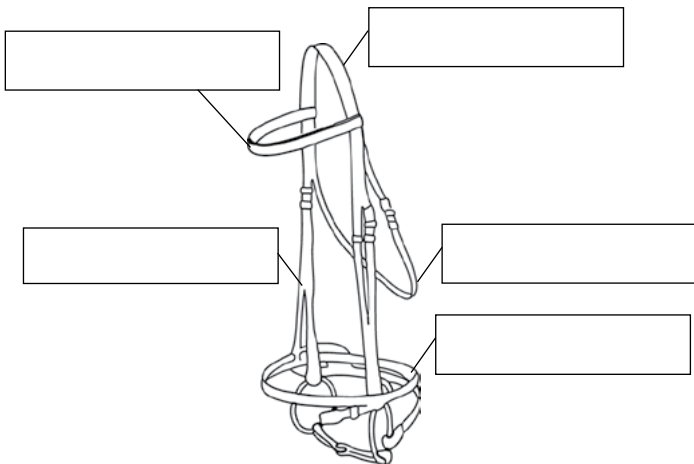

7. Number the order in which you would use the following grooming tools, with "1" as the first tool and "6" as the last.

- \_\_\_ Body brush
- \_\_\_ Mane and tail comb
- \_\_\_ Dandy brush
- \_\_\_ Cloth
- \_\_\_ Curry comb
- \_\_\_ Hoof pick

8. List three reasons why grooming is beneficial to your horse's health.

- 1.
- 2.
- 3.

9. Below are statements regarding catching and/or approaching a horse. Indicate whether the statements are true ("T") or false ("F").

- \_\_\_ When possible, approach the horse at an angle and come in near its shoulder.
- \_\_\_ Most horses are likely to jump and/or kick if they are startled.
- \_\_\_ If it is necessary to approach the horse from the rear, you should not speak to the horse to avoid startling it.
- \_\_\_ When behind the horse, you should stay close to its body.
- \_\_\_ You should use grain to catch a horse, even if other horses are present.

# KNOWLEDGE ADVANCEMENTS (contd.)

10. Match the following terms (on the left) to their definitions (on the right). Draw a line from the term to its definition.

- |             |                                     |
|-------------|-------------------------------------|
| A. Filly    | 1. An unweaned horse                |
| B. Mare     | 2. A male horse that is castrated   |
| C. Colt     | 3. Female horse under age 3         |
| D. Foal     | 4. A mature female, age 3 or older  |
| E. Gelding  | 5. A male horse able to sire a foal |
| F. Stallion | 6. Male horse under age 3           |

11. Name five items that you should take with you when you go on a trail ride.

- 1.
- 2.
- 3.
- 4.
- 5.

12. Identify the following parts of the western saddle. Write their names in the boxes.

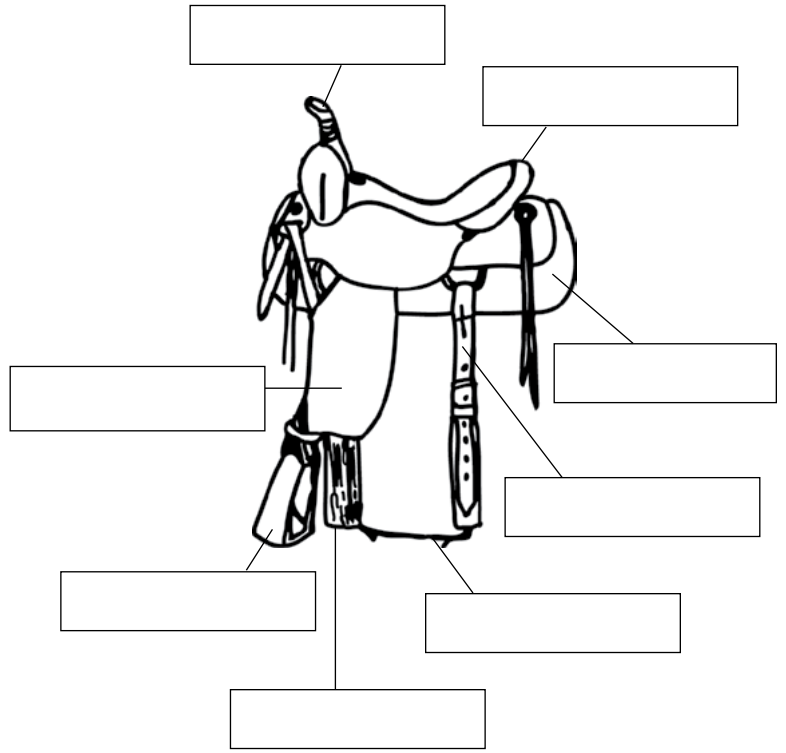

13. Identify the following parts of the western bridle. Write their names in the boxes.

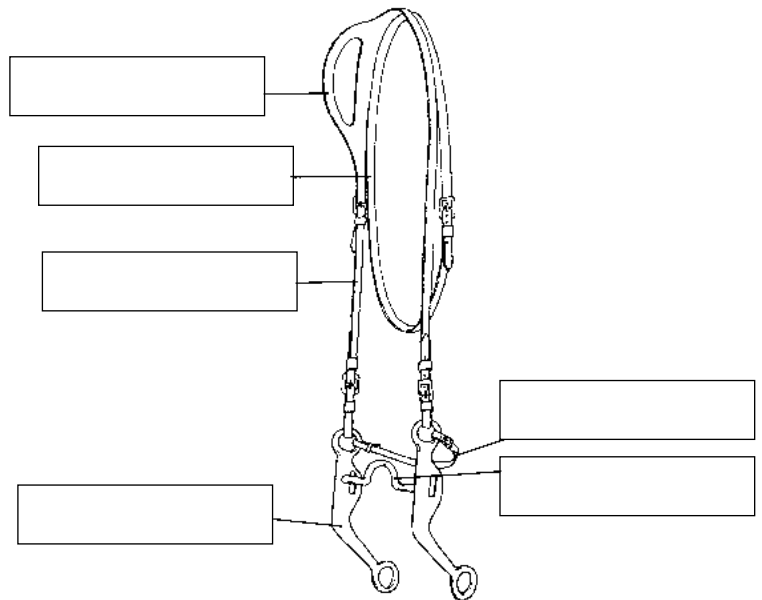

# 1 KNOWLEDGE ADVANCEMENTS (contd.)

14. On the pictures below, draw the following leg markings: coronet, pastern, ankle, sock (half-stocking), stocking, and full stocking.

CORONET

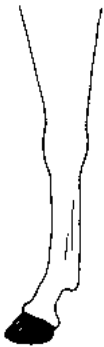

PASTERN



ANKLE

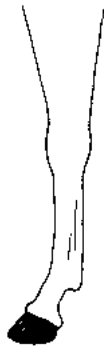

SOCK

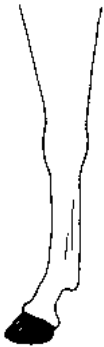

STOCKING



FULL STOCKING



15. On the picture below, draw a line indicating where you would measure the horse's height.

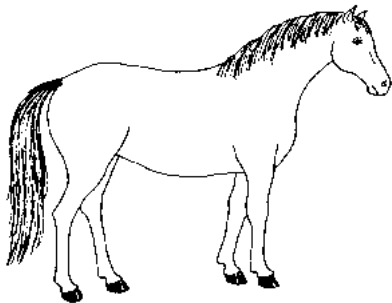

16. Match the following gaits (on the left) to their descriptions (on the right). Draw a line from the gait to its description.

A. Walk

1. Western term for slow trot

B. Sitting trot

2. Western term for the three-beat gait

C. Posting trot

3. English term for free-moving, two-beat gait

D. Canter

4. Four-beat gait

E. Jog

5. English term for smooth, three-beat gait

F. Lope

6. English term for a two-beat gait slower than a posting trot

17. Identify the following parts of the horse. Write their names in the boxes.

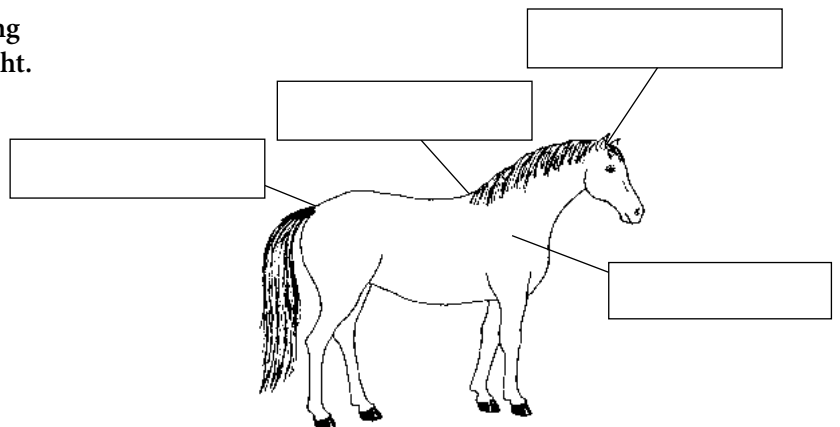

**Congratulations! You have successfully completed Level 1 of the Knowledge Advancements!**

\_\_\_\_\_ has satisfactorily completed all of the above knowledge elements and has, therefore, completed Level 1 of the Oregon 4-H Knowledge Advancements.

Name of Club Member

Leader's Signature: \_\_\_\_\_ Date Approved: \_\_\_\_\_

# 1 GROUND WORK ADVANCEMENTS

1. Ask your club leader to watch you perform the following ground work elements and sign off that you perform them accurately and safely.

| Element  | Date Completed | Leader's Initials |
|--|----------------|-------------------|
| Demonstrate proper quartering  |                |                   |
| Pose your horse (as in showmanship)                                  |                |                   |
| Back from the ground the requested number of steps                   |                |                   |
| Halter your horse (showing proper halter adjustment)                 |                |                   |
| Tie your horse with a quick-release knot                             |                |                   |
| Properly brush your horse  |                |                   |
| Lead your horse at a walk and trot from the near side                |                |                   |
| Perform a 90-degree haunch turn (both directions)                    |                |                   |
| Demonstrate how to properly approach and catch your horse            |                |                   |
| Show how to properly attach a chain over the nose and under the chin |                |                   |

2. What is the purpose of showmanship in 4-H?

\_\_\_\_\_

\_\_\_\_\_

\_\_\_\_\_

\_\_\_\_\_

3. If a chain is used in showmanship, approximately how long should it be?

\_\_\_\_\_ inches

4. What are the five areas of the horse you should clip for a show?

- 1.
- 2.
- 3.
- 4.
- 5.

**Congratulations! You have successfully completed Level 1 of the Ground Work Advancements!**

\_\_\_\_\_ has satisfactorily completed all of the above ground work elements and has, therefore, completed Level 1 of the Oregon 4-H Ground Work Advancements.

*Name of Club Member*

Leader's Signature: \_\_\_\_\_ Date Approved: \_\_\_\_\_

# 1 RIDING ADVANCEMENTS

1. Ask your club leader to watch you perform the following riding elements and sign off that you perform them accurately and safely.

| Element  | Date Completed | Leader's Initials |
|--|----------------|-------------------|
| Mount your horse from the near side  |                |                   |
| Dismount your horse from the near side   |                |                   |
| Perform a serpentine at a walk and trot  |                |                   |
| Canter/lope on the rail (both directions)  |                |                   |
| Halt from a walk, trot, and canter/lope  |                |                   |
| Perform a series of figure 8s at the trot, changing diagonals  |                |                   |
| Perform a series of figure 8s at the canter/lope, executing a simple change of lead  |                |                   |
| Perform a 180-degree haunch turn (both directions)   |                |                   |
| Perform a 180-degree forehand turn (both directions)   |                |                   |
| Perform a posting trot on a straightaway and change diagonals three times as requested by your leader (Dad Potter Step #7) |                |                   |
| Walk forward and backward the exact number of steps requested (Dad Potter Step #1)   |                |                   |

2. Describe one way to cue a horse to stop.

---



---



---

3. Describe one way to make a horse trot.

---



---



---

4. What are three aids (natural or artificial) that you might use when riding your horse?

- 1.
- 2.
- 3.

5. What are three things you should consider when choosing a riding instructor?

- 1.
- 2.
- 3.

**Congratulations! You have successfully completed Level 1 of the Riding Advancements!**

\_\_\_\_\_ has satisfactorily completed all of the above riding elements and has, therefore, completed Level 1 of the Oregon 4-H Riding Advancements.

*Name of Club Member*

Leader's Signature: \_\_\_\_\_ Date Approved: \_\_\_\_\_

# PERSONAL DEVELOPMENT ADVANCEMENTS

Members should complete at least two personal development options each year. Indicate the personal development options that you complete and ask your leader to sign off that you have completed them.

| Option   | Date Completed | Leader's Signature |
|--|----------------|--------------------|
| Lead the Pledge of Allegiance and the 4-H pledge at a club meeting | _____          | _____              |
| Observe a horse being shod   | _____          | _____              |
| Visit a tack store   | _____          | _____              |
| Read a horse book  | _____          | _____              |
| Attend a 4-H camp  | _____          | _____              |
| Serve as host for a 4-H meeting                                    | _____          | _____              |
| Give a presentation  | _____          | _____              |
| Create an educational display                                      | _____          | _____              |
| Participate in a judging contest                                   | _____          | _____              |
| Participate in a hippology contest                                 | _____          | _____              |
| Participate in a horse bowl contest                                | _____          | _____              |
| Participate in your county fair                                    | _____          | _____              |
| Participate in a community service project                         | _____          | _____              |
| Conduct a horse-related science inquiry                            | _____          | _____              |
| Other: _____   | _____          | _____              |
| Other: _____   | _____          | _____              |
| Other: _____   | _____          | _____              |

**Congratulations! You have successfully completed Level 1 of the Personal Development Advancements!**

\_\_\_\_\_ has satisfactorily performed the required amount of personal development options listed above and has, therefore, completed Level 1 of the Oregon 4-H Personal Development Advancements.

*Name of Club Member*

Leader's Signature: \_\_\_\_\_ Date Approved: \_\_\_\_\_